



# Installation Manual

Cummins **Onan**

Performance you rely on.™



## RV Generator Set

HDKCA (Spec A-E)

HDKCB (Spec A-E)

**California**

**Proposition 65 Warning**

Diesel engine exhaust and some of its constituents are known to the State of California to cause cancer, birth defects, and other reproductive harm.



**WARNING**



Do not use this genset on a boat  
Such use may violate U. S. Coast Guard  
regulations and can result in  
severe personal injury or death from  
fire, electrocution, or  
carbon monoxide poisoning



# Table of Contents

---

SECTION	PAGE
SAFETY PRECAUTIONS .....	iii
1. INTRODUCTION .....	1-1
About this Manual .....	1-1
Installation Codes and Standards for Safety .....	1-1
Outline Drawings .....	1-1
2. LOCATION, MOUNTING, AND VENTILATION .....	2-1
Location .....	2-1
Mounting .....	2-2
Ventilation .....	2-2
3. EXHAUST CONNECTIONS .....	3-1
Muffler .....	3-1
Tailpipe .....	3-2
4. FUEL CONNECTIONS .....	4-1
Bio-diesel Fuels B5 – B20 .....	4-2
5. ELECTRICAL CONNECTIONS .....	5-1
AC Power Output .....	5-1
Remote Control .....	5-3
Batteries .....	5-5
6. INSTALLATION REVIEW AND STARTUP .....	6-1
Installation Review .....	6-1
Startup .....	6-1
Hot Air Recirculation Test .....	6-2
7. SPECIFICATIONS .....	7-1
CONTROL SCHEMATIC .....	A-1
OUTLINE DRAWING .....	A-2



**THIS PAGE IS INTENDED TO BE BLANK**



# SAFETY PRECAUTIONS

---

Thoroughly read the **OPERATOR'S MANUAL** before operating the genset. Safe operation and top performance can only be obtained when equipment is operated and maintained properly.

The following symbols in this manual alert you to potential hazards to the operator, service person and equipment.

**⚠ DANGER** alerts you to an immediate hazard that will result in severe personal injury or death.

**⚠ WARNING** alerts you to a hazard or unsafe practice that can result in severe personal injury or death.

**⚠ CAUTION** alerts you to a hazard or unsafe practice that can result in personal injury or equipment damage.

Electricity, fuel, exhaust, moving parts and batteries present hazards which can result in severe personal injury or death.

## GENERAL PRECAUTIONS

- Keep children away from the genset.
- Do not use evaporative starting fluids. They are highly explosive.
- To prevent accidental or remote starting while working on the genset, disconnect the negative (-) battery cable at the battery.
- Let the engine cool down before removing the coolant pressure cap or opening the coolant drain. Hot coolant under pressure can spray out and cause severe burns.
- Keep the genset and its compartment clean. Excess oil and oily rags can catch fire. Dirt and gear stowed in the compartment can restrict cooling air.
- Make sure all fasteners are secure and torqued properly.

- Do not work on the genset when mentally or physically fatigued or after consuming alcohol or drugs.
- You must be trained and experienced to make adjustments while the genset is running—hot, moving or electrically live parts can cause severe personal injury or death.
- Used engine oil has been identified by some U. S. state and federal agencies as causing cancer or reproductive toxicity. Do not ingest, inhale, or contact used oil or its vapors.
- Ethylene glycol, used as engine antifreeze, is toxic to humans and animals. Clean up spills and dispose of used engine coolant in accordance with local environmental regulations.
- Keep multi-class ABC fire extinguishers handy. Class A fires involve ordinary combustible materials such as wood and cloth; Class B fires, combustible and flammable liquid fuels and gaseous fuels; Class C fires, live electrical equipment. (ref. NFPA No. 10)
- Genset installation and operation must comply with all applicable local, state and federal codes and regulations.

## GENERATOR VOLTAGE IS DEADLY

- Disable the automatic genset starting feature of an inverter-charger or other automatic starting device before servicing the genset.
- Generator electrical output connections must be made by a trained and experienced electrician in accordance with applicable codes.
- The genset must not be connected to the public utility or any other source of electrical power. Back-feed could lead to electrocution of utility personnel and damage to equipment. An approved switching device must be used to prevent interconnections.
- Use caution when working on live electrical equipment. Remove jewelry, make sure clothing and shoes are dry, stand on a dry wooden platform or rubber insulating mat and use tools with insulated handles.

## ENGINE EXHAUST IS DEADLY

- Inspect for exhaust leaks at every startup and after every eight hours of running.
- Prior to every startup and after every eight hours of running, all carbon monoxide detectors must be tested and confirmed to be working in accordance with the manufacturer's instructions or owners manual.
- Learn the symptoms of carbon monoxide poisoning in the Operator's Manual.
- Never occupy the vehicle while the genset is running unless the vehicle is equipped with a working carbon monoxide detector.
- Do not operate the genset when the vehicle is in a confined space, such as a garage.
- Disable the automatic genset starting feature of an inverter-charger or other automatic starting device before storing the vehicle or parking it in a garage or other confined space.
- The exhaust system must be installed in accordance with the genset Installation Manual.
- Engine cooling air must not be used for heating working or living spaces or compartments.

## DIESEL FUEL IS COMBUSTIBLE

- Do not smoke or turn electrical switches ON or OFF where fuel fumes are present or in areas sharing ventilation with fuel tanks or equipment. Keep flames, sparks, pilot lights, arc-producing equipment and all other sources of ignition well away.

- Fuel lines must be secured, free of leaks and separated or shielded from electrical wiring.

## BATTERY GAS IS EXPLOSIVE

- Wear safety glasses.
- Do not smoke.
- To reduce arcing when disconnecting or reconnecting battery cables, always disconnect the negative (-) battery cable first and reconnect it last.

## MOVING PARTS CAN CAUSE SEVERE PERSONAL INJURY OR DEATH

- Disable the automatic genset starting feature of an inverter-charger or other automatic starting device before servicing the genset.
- Do not wear loose clothing or jewelry near moving parts such as PTO shafts, fans, belts and pulleys.
- Keep hands away from moving parts.
- Keep guards in place over fans, belts, pulleys, and other moving parts.

## FLAMMABLE VAPOR CAN CAUSE A DIESEL ENGINE TO OVERSPEED

Flammable vapor can cause a diesel engine to overspeed and become difficult to stop, resulting in possible fire, explosion, severe personal injury and death. ***Do not operate a diesel-powered genset where a flammable vapor environment can be created by fuel spill, leak, etc.*** The owners and operators of the genset are solely responsible for operating the genset safely.

# 1. Introduction

## ABOUT THIS MANUAL

This manual is a guide for the installation of the generator sets (gensets) listed on the front cover. Proper installation is essential for top performance. Read through this manual before starting the installation.

This manual addresses the following aspects of the installation:

- Location and Mounting
- Exhaust Connections
- Fuel Connections
- Electrical Connections
- Startup

**⚠ WARNING** *This genset is not a life support system. It can stop without warning. Children, persons with physical or mental limitations, and pets could suffer personal injury or death. A personal attendant, redundant power or an alarm system must be used if genset operation is critical.*

**⚠ CAUTION** *Unauthorized modifications or replacement of fuel, exhaust, air intake or speed control system components that affect engine emissions are prohibited by law in the State of California.*

See the genset Operator's Manual for operation and maintenance.

**Note:** Manuals are updated from time to time to reflect changes in the equipment and its specifications. For this reason, only the copy of the installation manual supplied with the genset should be used as a guide for the installation.

## INSTALLATION CODES AND STANDARDS FOR SAFETY

The genset installer bears sole responsibility for the selection of the appropriate genset, for its proper installation and for obtaining approvals from the authorities (if any) having jurisdiction over the installation. These sets meet the basic requirements of the Standard for Safety for Engine Generator Sets for

Recreational Vehicles, ANSI/RVIA EGS-1. They are suitable for installation in accordance with:

- NFPA No. 1192—Recreational Vehicles
- NFPA No. 70, Article 551—Recreational Vehicles and RV Parks
- CSA Electrical Bulletin 946—Requirements for Internal Combustion Engine-Driven Electric Generators for Use in Recreational Vehicles

Federal, State and local codes, such as the California Administrative Code—Title 25 (RV installation), could also apply. Installation codes and recommendations can change from time to time and are different in different countries, states and municipalities. It is recommended that the standards in Table 1-1 be obtained for reference.

**TABLE 1-1. REFERENCE CODES AND STANDARDS**

Code of Federal Regulations, Title 49: Chapter III and Chapter V	Superintendent of Documents P. O. Box 371954 Pittsburgh, PA 15250-7954
NFPA No 70, 1192	National Fire Protection Association 470 Atlantic Avenue Boston, MA 02210
ANSI/RVIA-EGS-1	Recreational Vehicle Industry Association 14650 Lee Road Chantilly, VA 22021
California Administrative Code—Title 25, Chapter 3	State of California Documents Section P.O. Box 1015 North Highlands, CA 95660
CAN/CSA-Z240 Recreational Vehicles Bulletin 946	Canadian Standards Association Housing and Construction Materials Section 178 Rexdale Blvd. Rexdale, Ontario, Canada M9W 1R3

## OUTLINE DRAWINGS

See the Outline Drawing (Page A-2) for installation details: mounting bolt hole locations, connection points (fuel, battery, exhaust, remote control, AC output), sizes and types of fittings, cooling air openings, weight, service access points and overall dimensions. See your Onan dealer for a large-scale Outline Drawing and full-size floor cutout template.

**⚠ WARNING** *Improper installation can result in severe personal injury, death and equipment damage. The installer must be qualified to perform the installation of electrical and mechanical equipment.*



**THIS PAGE IS INTENDED TO BE BLANK**





## 2. Location, Mounting, and Ventilation

### LOCATION

Typical genset locations on a vehicle are illustrated in Figure 2-1.

1. Provide access to the operator's console, front and top service access doors, oil drain (bottom) and coolant drain (lower left front) so that all periodic maintenance can be performed in accordance with the Operator's Manual.
2. Provide access for connecting and disconnecting fuel lines, battery cables, remote control wiring and AC wiring.
3. Make sure that frame cross members, exhaust tail pipes and other equipment do not cross underneath the oil drain plug or air intake and discharge openings. These are the crosshatched areas on the Outline Drawing (Page A-2).
4. Make sure the genset clears the ground by at least 12 inches (305 mm) to provide adequate ventilation and reduce the amount of dust pulled in by the cooling fan.
5. Protect the air inlets in the bottom of the genset from road splash, especially when the genset is located in line with the road wheels. It is preferable to mount the genset in front of, rather than behind, the road wheels.
6. Provide a vapor-tight, fire-resistive barrier between the genset and the interior of the vehicle. Use approved materials (26 gauge galvanized steel or equivalent). See NFPA 1192 for details.

**⚠WARNING** *EXHAUST GAS IS DEADLY. Construct a suitable vapor barrier of approved materials between the genset and vehicle interior to keep out exhaust gas.*

7. A genset compartment must be large enough to provide at least 1/2 inch (12.5 mm) clearance at the top of the genset and 1/4 inch (6.4 mm) clearance at the sides. These minimum clearances apply to the thermal or acoustic insulation with which the compartment may be lined.
8. Acoustic/thermal insulation and adhesive must be Classified as "Self-Extinguishing" at not less than 200°F (90°C). Do not line the bottom of the compartment with insulation, which absorbs spilled fuel and oil.

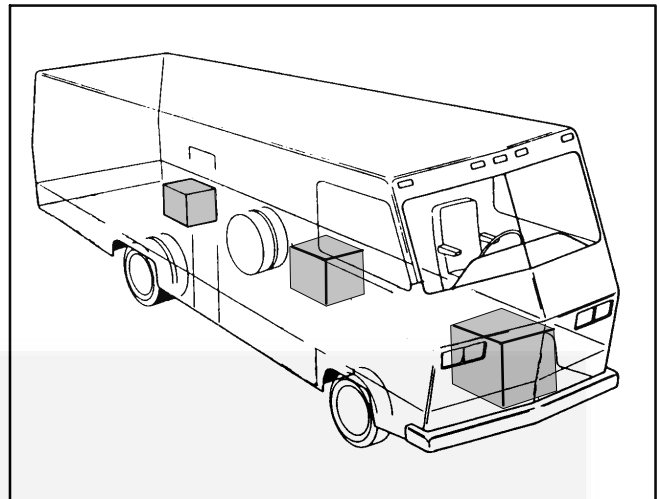

FIGURE 2-1. TYPICAL GENSET LOCATIONS

## MOUNTING

Support the genset on a structure able to resist the dynamic weight of the genset:  $\pm 3$  g-force vertical and  $\pm 1$  g-force horizontal. See *Section 7. Specifications* for the weight of the genset. Use four Grade 5, 3/8-16 UNC screws to secure the genset vibration isolating sub-frame to the floor or frame. Torque the screws to 35 lb-ft (41 N-m).

A vibration isolator kit is available for models that do not have the external vibration isolators and frame illustrated in Figure 2-2. Follow the instructions in the vibration isolator kit.

**⚠WARNING** *The genset support structure must be designed and installed to support and restrain the dynamic weight of the genset. Failure to do so can result in the genset dropping onto the roadway causing property damage, severe personal injury and death.*

## VENTILATION

Unrestricted air flow for cooling, ventilation and combustion is essential for proper genset perfor-

mance and service life (Figure 2-2). The air intake and discharge openings are in the bottom of the genset. These are the crosshatched areas on the Outline Drawing (Page A-2). See also *Hot Air Recirculation Test* (Page 6-2).

If the genset is installed on a floor, cut out openings in the floor that are at least as large as the openings in the genset. The openings must line up so that the air can flow straight through the space between the genset opening and the floor cutout opening. *If necessary, duct the hot discharge air through the floor to prevent recirculation inside the compartment.*

Make sure frame cross members, exhaust tail pipes and other equipment do not cross underneath the air intake and discharge openings. *Do not block the air inlet and outlet openings with screens, expanded metal or the like; they restrict air flow and could cause the genset to overheat.*

**Note:** The hot air discharges away from the end of the genset at a slight angle to reduce recirculation (Figure 2-2). This space must also be free of frame cross members, exhaust tail pipes and other equipment that could deflect the discharged air back into the air intake openings.

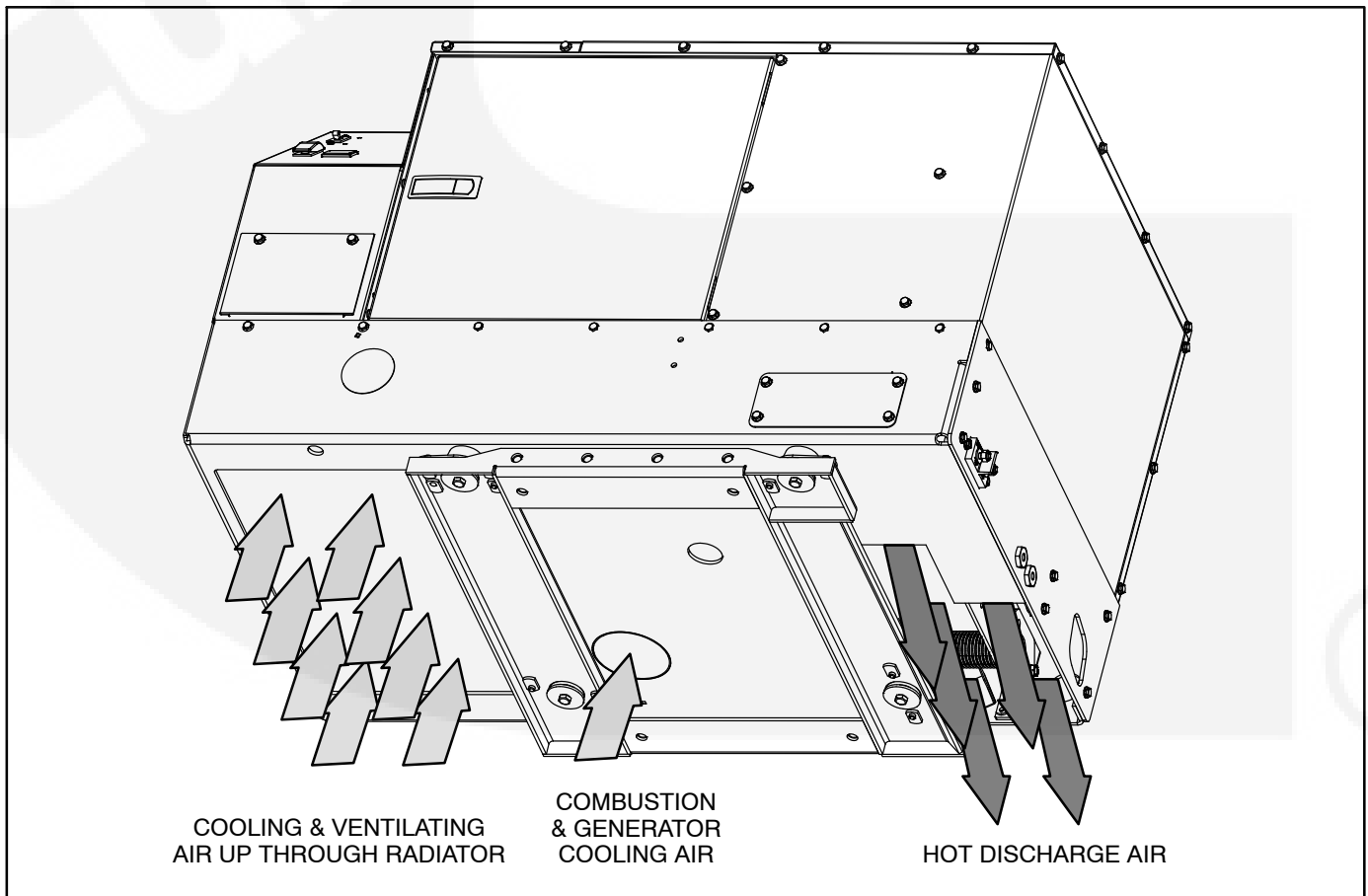

FIGURE 2-2. COOLING, VENTILATION AND COMBUSTION AIR FLOWS

# 3. Exhaust Connections

The exhaust system must be gas-tight and designed to limit entry of exhaust gases into the vehicle.

**⚠WARNING** *EXHAUST GAS IS DEADLY! To keep exhaust gases from entering the vehicle do not terminate the exhaust tailpipe underneath the vehicle or closer than specified to openings into the vehicle (Figure 3-4) or route it such that it is likely to be damaged (Figure 3-5). Use approved materials and parts only.*

**⚠CAUTION** *Unauthorized modifications or replacement of fuel, exhaust, air intake or speed control system components that affect engine emissions are prohibited by law in the State of California.*

## MUFFLER

The muffler is mounted inside the genset housing. It

has a USDA (Forest Service) spark arrestor and meets RVIA EGS-1 construction requirements.

Figure 3-1 illustrates the flanged exhaust outlet and the clearance openings for rear and side tail pipe connections. See the Outline Drawing (Page A-2) for the dimensions of the exhaust outlet flange.

A genset without a properly installed and maintained spark arresting exhaust system can cause a brush or forest fire, and is illegal on federal lands. Liability for damage, injury and warranty expense due to the modification of the exhaust system or to use of unapproved parts is the responsibility of the person performing the modification or installing the unapproved parts. Contact an Onan distributor for approved exhaust system parts.

**Note:** Block the side and rear exhaust exit openings in the base if the genset is mounted in an enclosure and the *Hot Air Recirculation Test* (Page 6-2) indicates there is recirculation that could cause the genset to overheat.

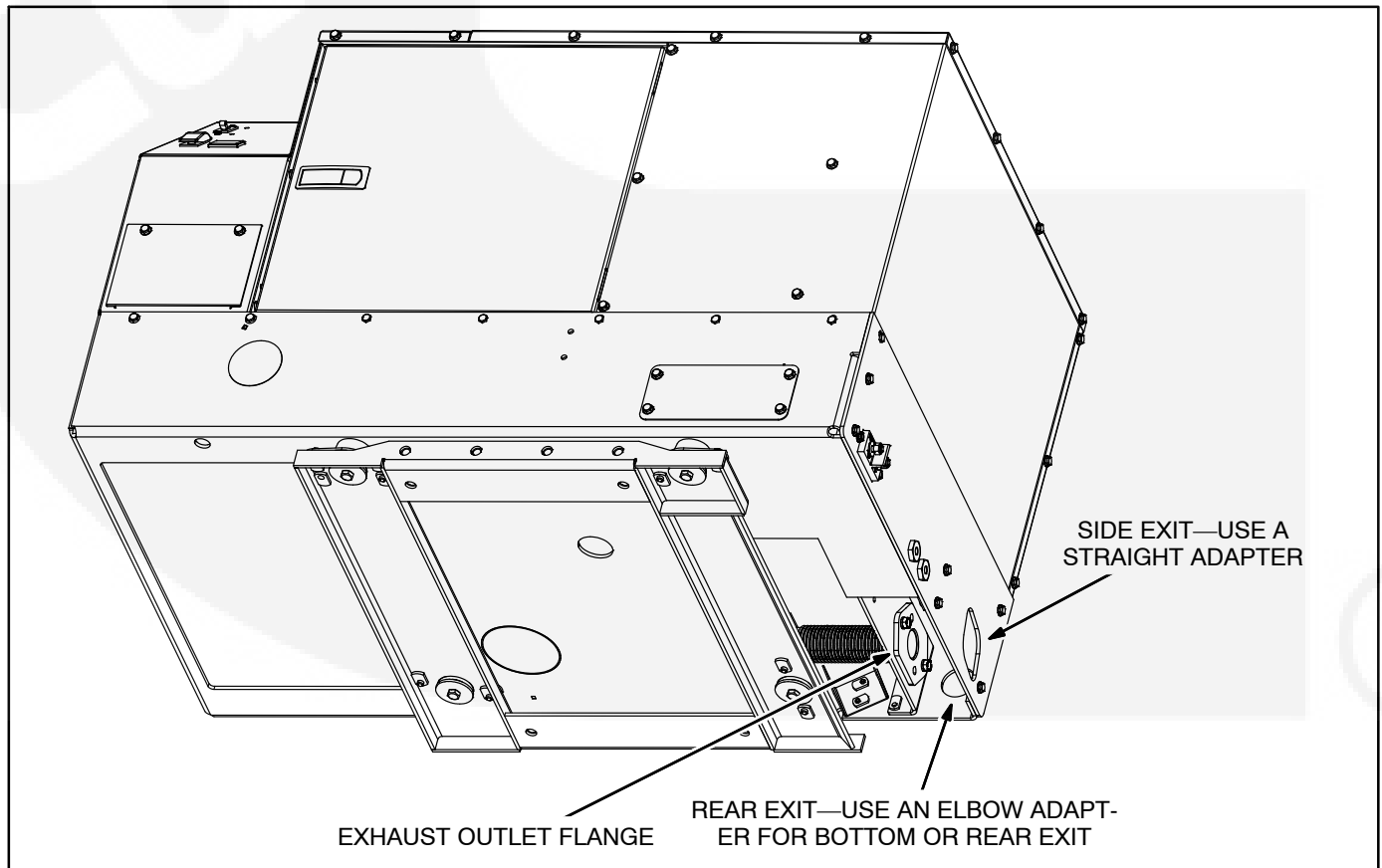

FIGURE 3-1. EXHAUST CONNECTIONS AT GENSET

## TAILPIPE

Tailpipe adapter kits are separately available. Use a straight adapter for a tailpipe routed through the side clearance hole. Use an elbow adapter for a tailpipe routed through the rear clearance hole or up from below. When connecting and routing the tailpipe:

1. Use 1-3/8 inch ID, 18-gauge aluminized steel tubing or equivalent for the tailpipe. (Do not use flexible pipe. Flexible pipe is not gas tight or durable.)
2. Secure the tailpipe or adapter flange to the muffler flange with a gasket and two stainless steel M8 x 1.25 bolts, which are supplied.
3. Use U-bolt muffler clamps to connect sections of tailpipe. It is recommended that the overlapping pipe be slotted as shown in Figure 3-2.
4. Use automotive-type tailpipe hangers every 2 to 3 feet (0.6 to 0.9 m). Attach the hangers to steel framework, not to wood or other combustible material.
5. Do not terminate the tailpipe underneath the vehicle. Extend it a minimum of 1 inch (25 mm) beyond the perimeter of the vehicle (Figure 3-3). Support the end of the tailpipe such that it cannot be pushed inward and up under the skirt of the vehicle by backing up into a curb or other obstacle.

**Note: Do not terminate the tailpipe underneath a slide-out room (Figure 3-5), unless the bottom of the slide-out, including skirts and moldings, is at least 3 feet above the end of the tailpipe.**

6. Do not route the tailpipe such that it will interfere with draining engine oil or coolant or restrict the air inlet.
7. Do not route the tailpipe closer than 3 inches (76 mm) to combustible material (wood, felt, cotton, organic fibers, etc.) unless it is insulated or shielded. The temperature rise (above ambient) on adjacent combustible material must not exceed 117°F (65°C).
8. Do not route the tail pipe near fuel lines or fuel tanks or terminate it below or near a fuel fill opening.
9. Do not terminate the tailpipe such that it is closer than 6 inches (153 mm) to any opening into the vehicle interior (door, window, vent). See Figure 3-4.

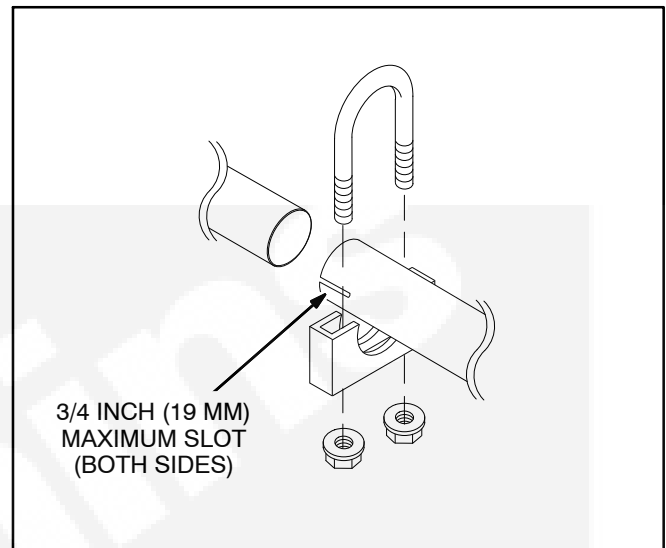

FIGURE 3-2. EXHAUST TAILPIPE CONNECTIONS

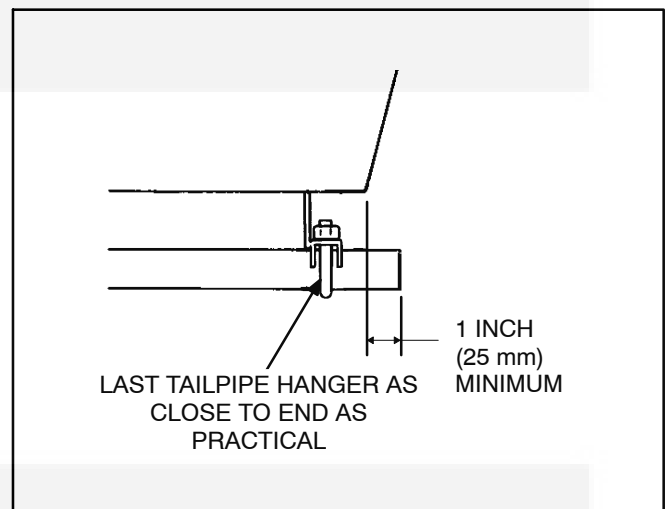

FIGURE 3-3. TERMINATING THE EXHAUST TAILPIPE

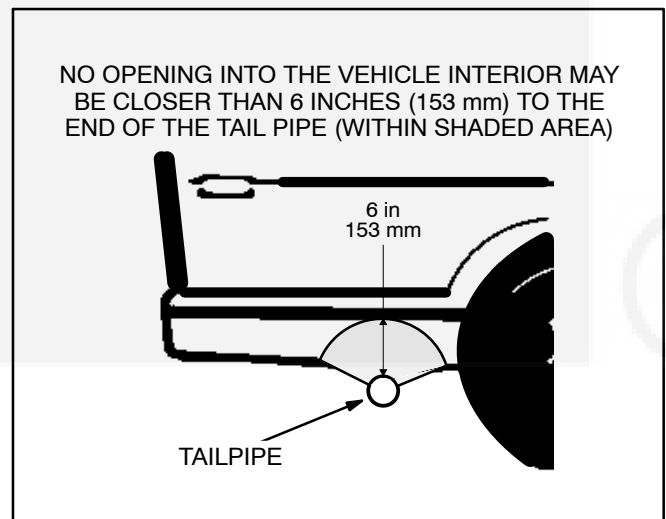

FIGURE 3-4. MINIMUM DISTANCES TO OPENINGS

10. Route the tailpipe such that it will not likely be struck when the vehicle is moving. At least keep it out of the approach and departure angles of the vehicle and above the axle clearance line (Figure 3-5).

**CAUTION** *Interconnecting the engine exhaust systems will allow exhaust condensates and soot to migrate into the engine that is idle, causing engine damage.*

11. Do not connect the genset to the vehicle engine exhaust system.

**CAUTION** *Excessive back pressure can cause loss of performance and engine damage.*

12. Exhaust back pressure under full load must not exceed 2 inches (51 mm) water column (WC) as measured within 6 inches (154 mm) of the muffler outlet flange.

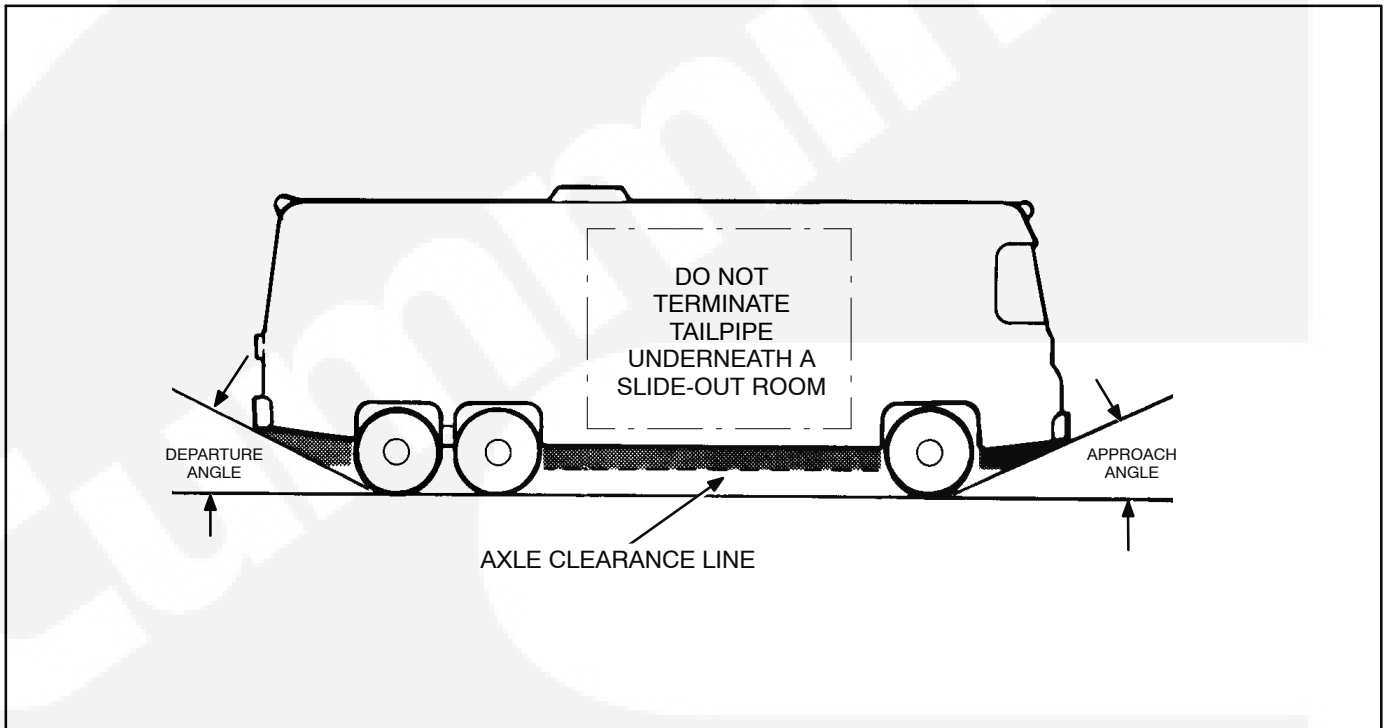

FIGURE 3-5. APPROACH AND DEPARTURE ANGLES AND AXLE CLEARANCE LINE



**THIS PAGE IS INTENDED TO BE BLANK**



## 4. Fuel Connections

**⚠ WARNING** Diesel fuel is a combustible and can cause severe personal injury or death. Do not smoke or allow any flame, spark, pilot light, arc-producing equipment, electrical switch or other ignition source around fuel or fuel components, or in areas sharing ventilation. Keep a type ABC fire extinguisher handy.

Do not interconnect genset and vehicle engine fuel lines. Follow the vehicle chassis manufacturer's instructions when making connections to the vehicle engine fuel tank.

**⚠ CAUTION** Either or both engines could starve for fuel if the genset and vehicle engine fuel lines are interconnected. Always use separate fuel lines or a separate fuel tank for the genset.

To prevent the genset from running the vehicle out of fuel, do not extend the genset fuel pickup tube down into the fuel tank as far as the pickup tube for the vehicle engine.

Fuel lines (supply and return) must have at least a 1/4 inch (6.4 mm) ID. See Figure 4-1 for connections at the genset.

Run the fuel line at or above the top of the fuel tank to reduce the risk of siphoning fuel out of the tank if the line should break. The maximum fuel pump lift is 36 inches (1 meter).

Route fuel lines away from electrical wiring and hot engine exhaust components. Fuel lines should be accessible for inspection and replacement, protected from damage and secured to prevent kinking, contact with sharp edges and chafing due to vibration.

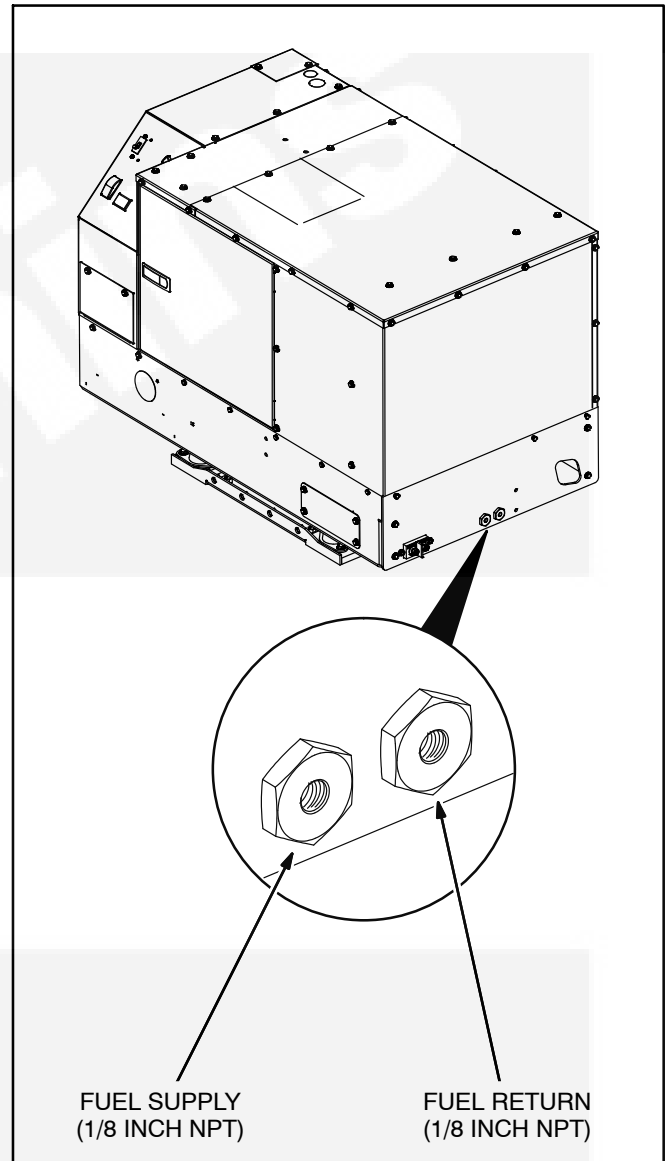

**FIGURE 4-1. FUEL CONNECTIONS**

## BIO-DIESEL FUELS B5 – B20

### Approved Bio-Diesel Fuel:

- Bio-diesel meeting either ASTM D6751 or EN14214.
- Fuel meeting either ASTM D6751 or EN14214 fuel can be blended with an acceptable diesel fuel meeting ASTM D975 meeting ASTM D975 up to 20 percent volume concentration (B20).

For bio-diesel blends above B5 and up to B20 the following installation requirements must be met:

- Supply and Return fuel lines and fittings must be bio-diesel compatible. Not all fuel hoses and fittings are bio-diesel compatible. All fuel wetted components must not contain the following materials: copper, brass, bronze, zinc, lead, tin, natural rubber and nitrile rubber compounds. Check with your manufacturer for bio-diesel compatibility.
- Fuel tanks must be made from the following materials: aluminum, steel, fluorinated polyethylene, fluorinated polypropylene or Teflon (PTFE).
- Verify the vehicle propulsion engine is capable of using B20 when sharing the same fuel tank with the generator set.
- A bio-diesel compatible fuel water separator is required. Cummins Onan strongly recommends using Cummins Filtration filters equipped with StrataPore™ media. This filter media removes water more efficiently than standard cellulosic filter media, which will not provide adequate fuel water separation capabilities. However, even StrataPore™ fuel filter media is not as effective in removing water from bio-diesel as it is in removing water from petro diesel. Therefore, preventing water from entering the fuel supply (vehicle or storage) remains very important.

Place the fuel water separator in a location that is accessible for service by as close the generator set as possible. Locating the separator ahead of the generator set fuel pump is acceptable.

### Additional information:

- Bio-diesel blends have higher pour and cloud points than standard diesel fuels. Generator set locations far from the fuel tank combined with low fuel flow rates can make the generator set fuel system very susceptible to fuel starvation related to gelling in cold weather (below 23°F/ -5°C). In addition to electric or coolant tank heaters, consideration to routing and possible heating or insulation of the fuel lines to the generator set may be needed.
- Bio-Diesel blends can oxidize more quickly than standard diesel fuels; more frequent fuel filter service intervals may be required and shorter fuel storage life in tanks is likely.

**⚠WARNING** It is highly recommended that specific market applications are avoided or exercised with extra care due to some of the properties of bio-diesel fuel blends such as cold weather operation, long term storage, material incompatibilities and other effects on engine operating characteristics. Such applications that should use standard fuels include applications that will experience seasonal usage, storage for periods exceeding 60 days, and extreme temperatures or humidity.

### Storage requirements:

- If using bio-diesel for seasonal applications (stored more than 90 days), the generator set must be purged before storage by running the engine on pure diesel fuel meeting ASTM D975 for a minimum of 30 minutes.





**TABLE 4-1. CUMMINS ONAN BIO-DIESEL RECOMMENDATIONS**

<b>APPLICATION</b>	<b>RECOMMENDATION FOR BIO-DIESEL BLENDS</b>	<b>RECOMMENDATIONS</b>	<b>COMMENTS</b>
Emergency Standby RV Seasonal/Commercial with low annual hour accumulation	Not Recommended	Use petroleum diesel only.	Low fuel usage and critical start nature of Emergency Standby make bio-diesel impractical.
Limited Time Prime	Approved with Recommendations	Use fuel within 6 months of manufacture. Flush fuel system with petroleum diesel prior to storage.	Bio-diesel is suitable for constant high load operation with proper precautions.
Unlimited Time Prime	Approved with Recommendations	Use fuel within 6 months of manufacture. Flush fuel system with petroleum diesel prior to storage/transport.	Bio-diesel is suitable for variable load operation with proper precautions.
Continuous	Approved with Recommendations	Use fuel within 6 months of manufacture.	Bio-diesel is suitable for base load operation with proper precautions.





**THIS PAGE IS INTENDED TO BE BLANK**



# 5. Electrical Connections

To prevent accidental starting of the genset during installation, do not connect the battery cables at the battery until so instructed in *Section 6. Installation Review and Startup* and make sure an automatic genset starting system is disabled.

**⚠WARNING** *Accidental starting of the genset can cause severe personal injury or death. Do not connect the starting battery until so instructed in Installation Review and Startup. Make sure an automatic genset starting system is disabled.*

## AC POWER OUTPUT

The genset is equipped with a terminal block and conduit connector knockouts for AC power output connections (Figure 5-1).

### Wiring Methods

Follow the National Electrical Code, especially noting the following:

1. Have a trained and experienced electrician supervise and inspect the installation of all AC wiring.
2. Secure only one lead at each AC output terminal. The terminals are suitable for wire sizes up to No. 6 AWG.
3. Use vibration-proof switches and controls to prevent the opening and closing of circuits while the vehicle is in motion.
4. Use rain-tight conduit, conduit connectors and junction boxes for all exterior wiring.
5. Provide ground fault circuit interrupters (GFCIs) for all convenience power receptacles.

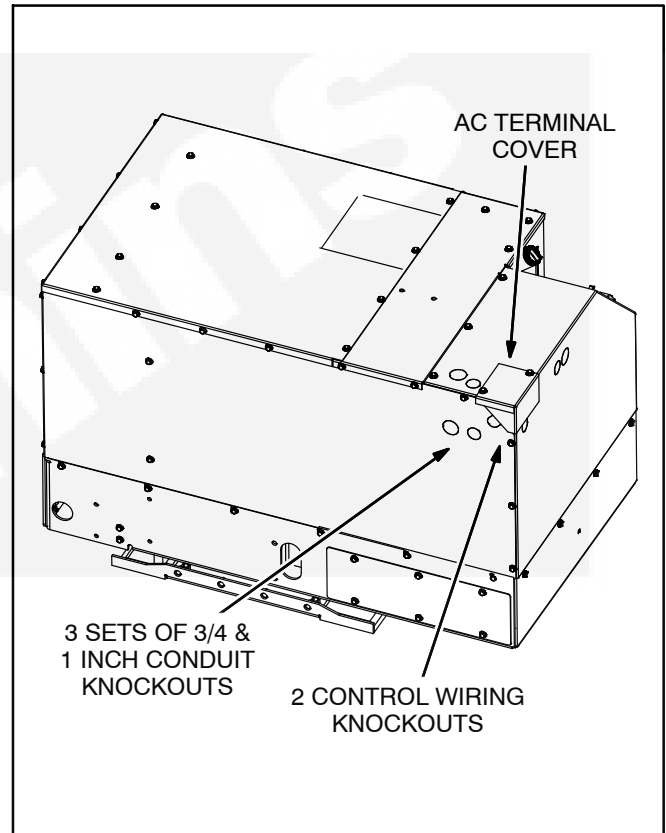

**FIGURE 5-1. ACCESS FOR AC OUTPUT AND REMOTE CONTROL CONNECTIONS**

- Seal all conduit openings into the vehicle interior to keep out exhaust gas. Apply silicone rubber or equivalent sealant inside and outside each conduit connector. (Flexible conduit is not vapor-tight and will allow exhaust gas to enter along the wires if not sealed.)

**⚠️WARNING** **EXHAUST GAS IS DEADLY!**  
**Seal all wiring openings into the vehicle interior to keep out exhaust gas.**

- Route or protect AC wiring so that it will not be cut or abraded, exposed to hot surfaces or damaged by road debris. Keep AC wiring away from fuel lines and control wiring (see Remote Control).

**⚠️WARNING** **Routing AC wiring with fuel lines can lead to fire and severe personal injury or death. Keep AC wiring away from fuel lines.**

- Connect the grounding terminal (Terminal TB2-4, Figure 5-2) in accordance with applicable codes.

**⚠️WARNING** **Faulty grounding can lead to fire or electrocution and severe personal injury or death. Grounding must be in accordance with applicable codes.**

### Connecting the Vehicle to Utility Power

A vehicle with provisions for connecting utility (shore) power must have an approved device to keep the genset and utility from being interconnected. See Figure 5-2 for typical connections.

**⚠️WARNING** **Interconnecting the genset and the public utility (or any other power source) can lead to electrocution of utility line workers, equipment damage and fire. Use an approved switching device to prevent interconnections.**

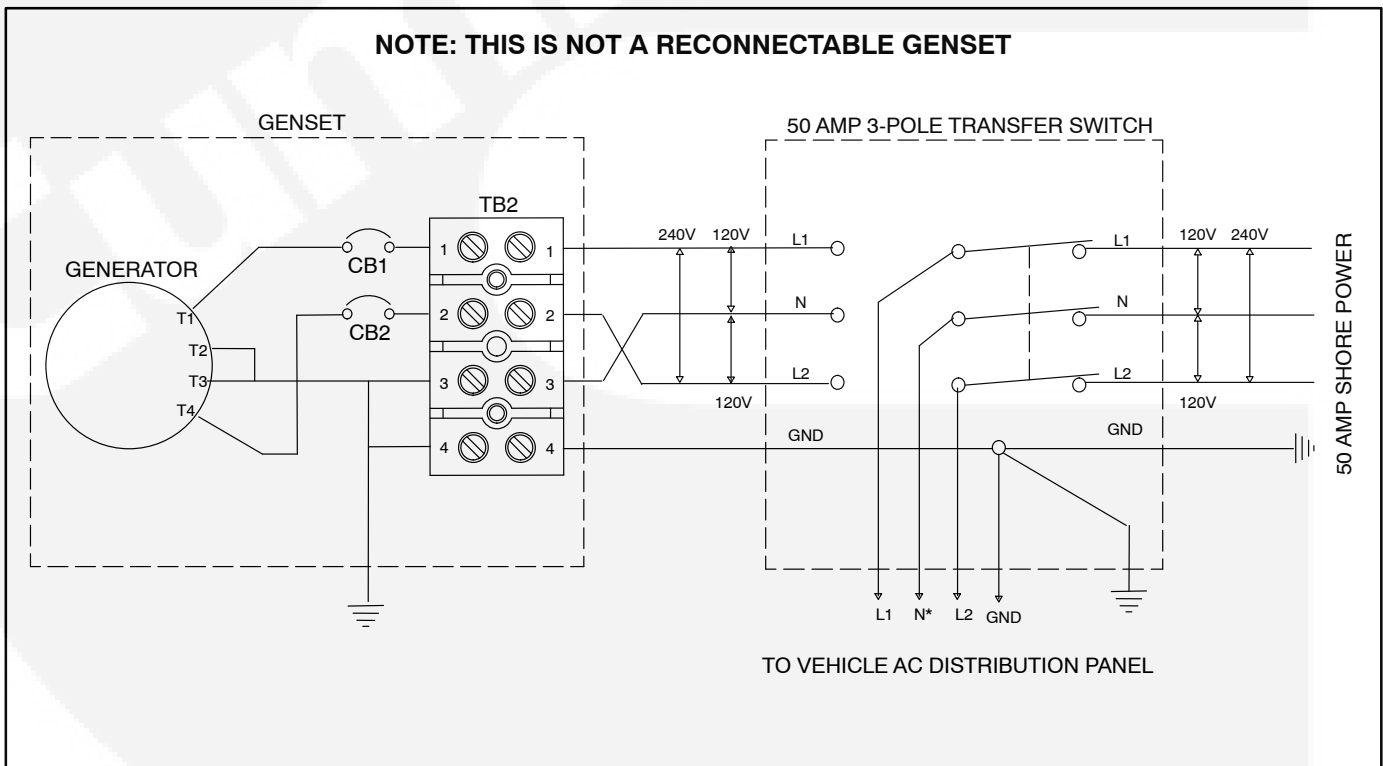

**FIGURE 5-2. TYPICAL AC CONNECTIONS**

## REMOTE CONTROL

Leads for connection to a remote control panel are terminated in a 10-pin sealed connector and are stowed inside the AC terminal enclosure when the

genset leaves the factory. See the Outline Drawing (Page A-2) for details of the connector and its mate. Refer to Figure 5-3 for pin connections. For further reference also see the Wiring Schematic (Page A-1).

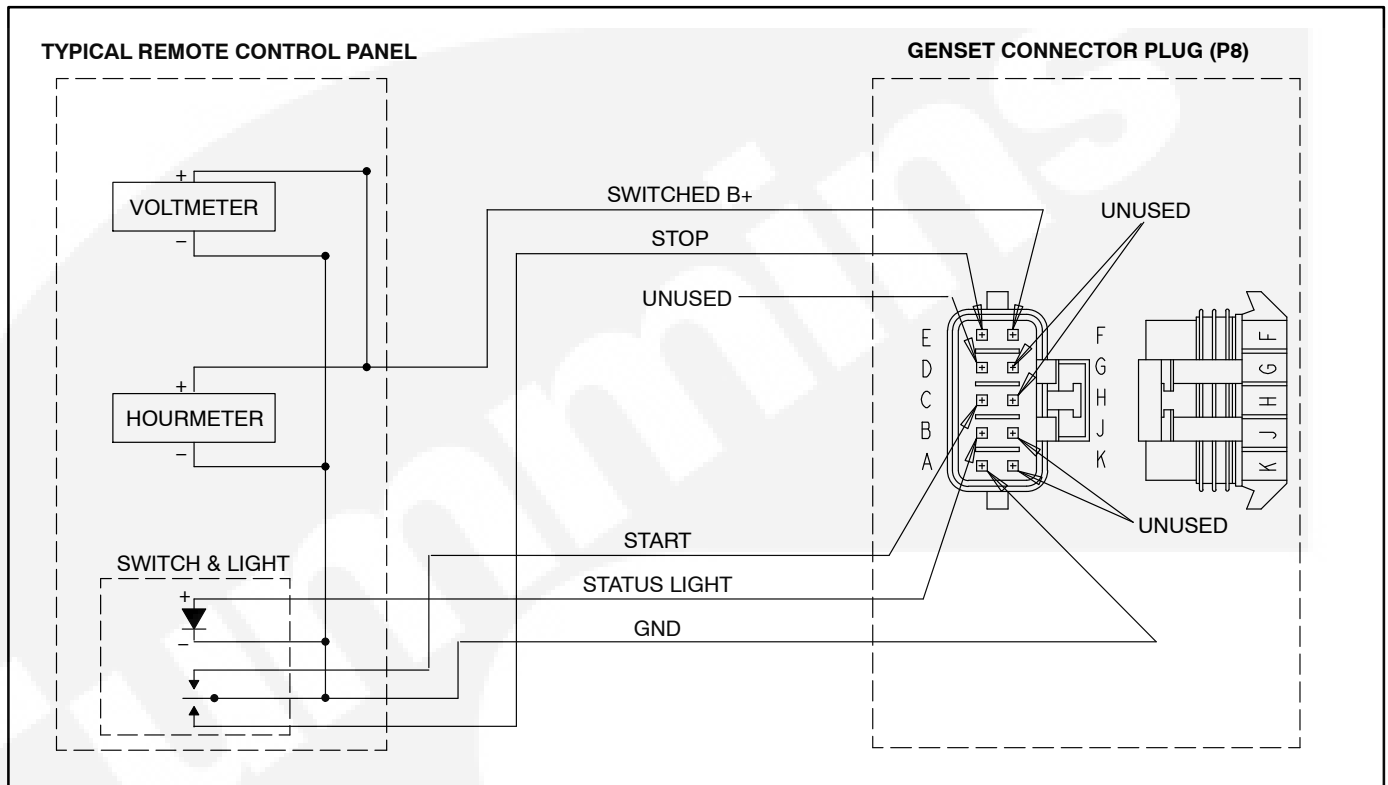

FIGURE 5-3. REMOTE CONTROL CONNECTOR PLUG AND TYPICAL CONNECTIONS

## Remote Control Panels

Onan offers harnesses of various lengths with mating receptacles and three remote control kits as follows:

- Remote switch / status lamp (Figure 5-4).
- Remote switch / status lamp and hour meter (Figure 5-5).
- Remote switch / status lamp and DC voltmeter (Figure 5-6).

If another source is used for the remote panel:

1. The control switch should be a two-pole, momentary-contact, center-return/center-off type of switch with an indicator light.
2. The total load connected to **P2-E** (Switched B+) should not exceed 2 amp.
3. The total load connected to **P2-F** (Status Light) should not exceed 2 amp.

### Wiring Methods

1. Remove the AC terminal access cover and remove one of the control wiring knockouts.
2. Pull out the remote control connector plug, fit the bushing around the connector leads into the knockout slot and secure the access cover.
3. Snap the connector plug and harness receptacle together.
4. If the harness does not have a plug for connections at the control panel, use solder-type butt connectors and heat-shrink insulation tubing to connect to the wiring from the remote panel. Use insulated 18 AWG copper conductors for the wiring from the remote panel.
5. Keep control leads away from AC power leads to reduce the possibility of erratic operation due to induced signals.
6. Seal the hole where the leads enter the interior of the vehicle to keep out exhaust gas. Use silicone rubber or an equivalent type of sealant.

**⚠WARNING** **EXHAUST GAS IS DEADLY!**  
**Seal all wiring openings into the vehicle interior to keep out exhaust gas.**

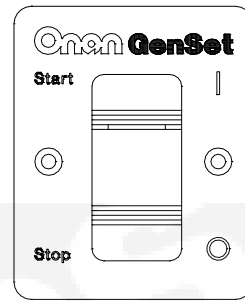

FIGURE 5-4. REMOTE SWITCH

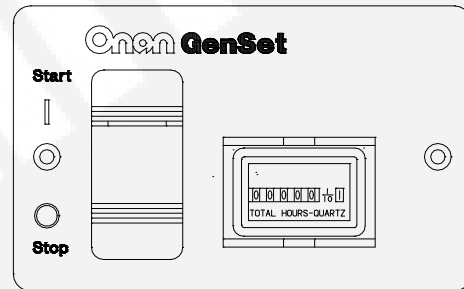

FIGURE 5-5. REMOTE SWITCH / HOUR METER

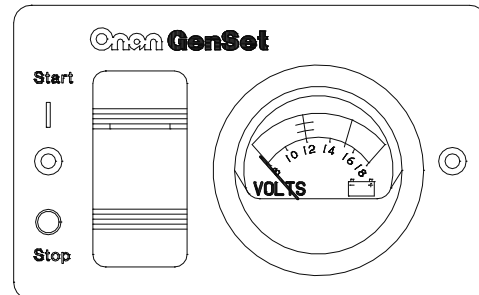

FIGURE 5-6. REMOTE SWITCH / DC VOLTMETER

## BATTERIES

To prevent accidental starting of the genset during installation, do not connect the battery cables at the battery until so instructed in *Section 6. Installation Review and Startup* and make sure an automatic genset starting system is disabled.

**⚠WARNING** *Accidental starting of the genset can cause severe personal injury or death. Do not connect the starting battery until so instructed in Installation Review and Startup. Make sure an automatic genset starting system is disabled.*

### Battery Capacity

The genset has a 12 VDC, negative-ground control and starting system. See *Specifications* for the requirements for cranking batteries.

### Battery Recharging

An external battery charger will need to be provided to recharge the genset cranking battery.

### Battery Compartment

Batteries must be mounted in a separate compartment from that of the genset and away from spark-producing equipment. An enclosed compartment must have openings of at least 1.7 square inches (11 square centimeters) at the top and bottom for ventilation of battery gasses. Batteries should be mounted such that spills and leaks will not drip acid on fuel lines, wiring and other equipment that could be damaged.

**⚠WARNING** *Arcing can ignite the explosive hydrogen gas given off by the battery, causing severe personal injury. The battery compartment must be ventilated and must isolate the battery from spark-producing equipment.*



## Battery Cables

Size battery cables according to Table 5-1. The current path between the genset and the negative (-) battery terminal must also be able to carry full cranking current without causing excessive voltage drop. It is highly recommended that a full-length cable be used to connect the genset to the negative (-) battery terminal (Figure 5-7). Note also that codes may require a bonding conductor between the genset and vehicle frame and between the battery and vehicle frame.

If the vehicle frame is used as the path between the negative (-) battery terminal and the genset (Figure 5-8), all frame members in the path of battery cranking currents must have substantial cross sections. The electrical resistance of riveted or bolted frame joints must also be carefully considered, especially if the joints will be exposed to corrosive conditions. A cable sized according to Table 5-1 must be used to connect the frame to the designated negative (-) terminal on the genset (Figure 5-8). **The genset mounting bolts are not considered adequate means for bonding the genset to the vehicle frame, either for the purpose of carrying cranking currents or for complying with requirements for genset/system grounding.**

Route battery cables away from fuel lines and hot engine exhaust components. Battery cables should be accessible for inspection and replacement, protected from damage and secured to prevent chafing due to vibration.

**⚠WARNING** *Routing battery cables with fuel lines can lead to fire and severe personal injury or death. Keep battery cables away from fuel lines.*

**TABLE 5-1. BATTERY CABLE SIZES FOR AMBIENT TEMPERATURES TO -20° F (-29° C)**

TOTAL CABLE LENGTH, FEET (METERS)*	CABLE SIZE, AWG
0 to 25 (0 to 7.6)	0
26 to 70 (8 to 21.3)	00
73 to 90 (22.25 to 27.4)	000

\* - Battery cable lengths are total lengths from the battery to the generator back to battery.  
Based on 300 amp cranking amperage.

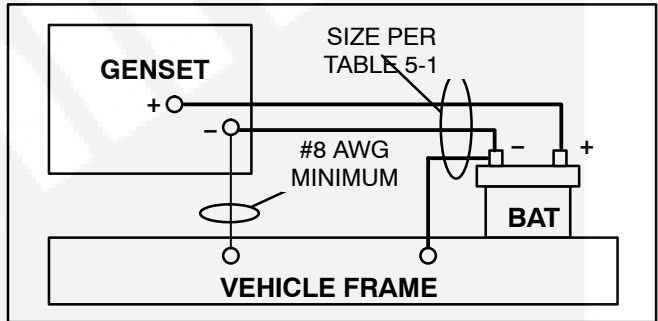

**FIGURE 5-7. FULL-LENGTH CABLE FROM BATTERY NEGATIVE (-) TERMINAL**

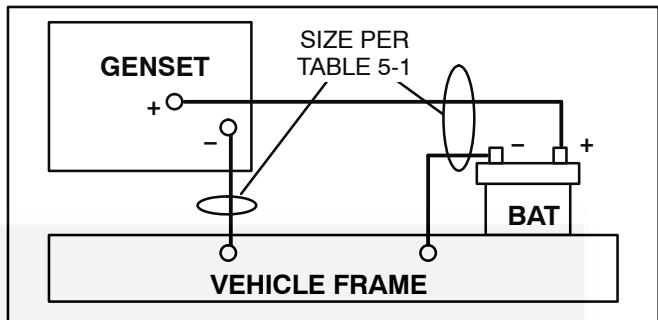

**FIGURE 5-8. VEHICLE FRAME AS PATH FROM BATTERY NEGATIVE (-) TERMINAL**



## Genset Bonding Terminal

The negative (-) battery cable terminal shown in Figure 5-9 is also the bonding terminal for grounding the genset to the vehicle chassis. If the grounding cable is also going to carry starter motor current, it must be sized the same as the battery cables.

## Connecting Battery and Bonding Cables

Terminate the battery cables with ring terminals sized for the 5/16 inch genset terminal screws (Figure 5-9). Permanently mark each end of each cable as to its polarity, positive (+) or negative (-). After making sure the battery cables are not connected at the battery and that an automatic genset starting system is disabled, connect the battery and grounding cables to the genset.

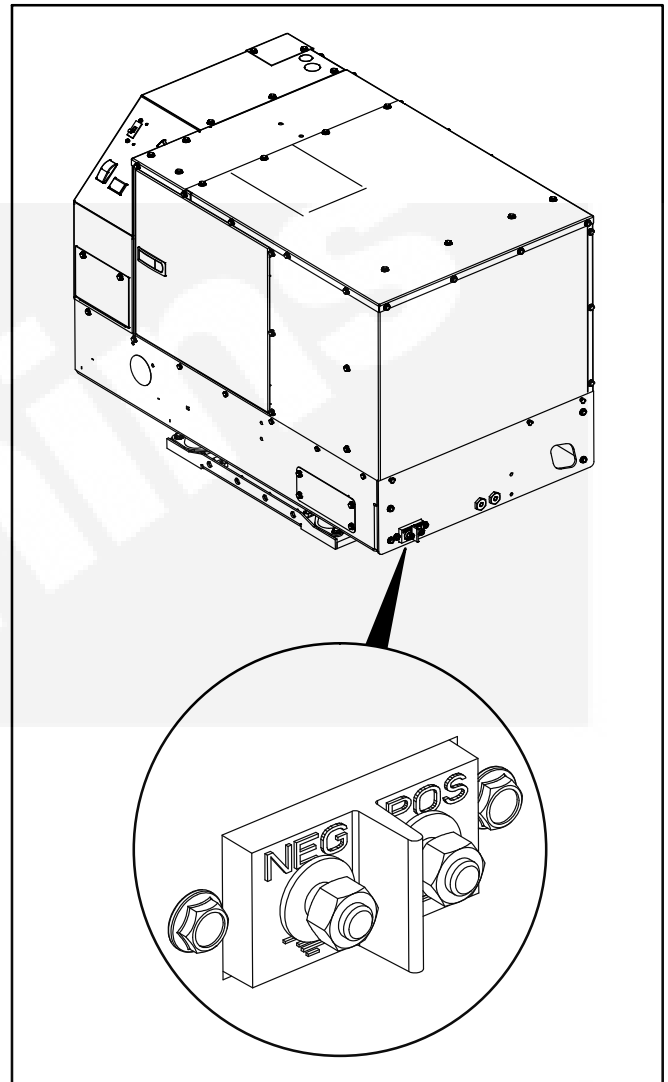

FIGURE 5-9. BATTERY CABLE TERMINALS



**THIS PAGE IS INTENDED TO BE BLANK**



# 6. Installation Review and Startup

---

## INSTALLATION REVIEW

Before starting the genset inspect the installation and check off (✓) each of the following questions if it can be answered “YES”. If a question cannot be checked off, review the appropriate section in the manual.

- [ ] Is the operator’s console easily accessible for starting and stopping the genset, resetting circuit breakers and checking and adding engine coolant?
- [ ] Is the genset securely bolted in place?
- [ ] Is there clearance all around the genset?
- [ ] Are the cooling and combustion air inlet and outlet openings free of obstructions?
- [ ] Is there easy access for draining the engine oil?
- [ ] Is there easy access for draining the engine coolant?
- [ ] Is there easy access for changing the air filter, checking oil level and adding oil?
- [ ] Is there easy access (through the top service access cover) for cleaning out the spark-arrest muffler?
- [ ] Are all tailpipe connections tight and all hangers and support straps secure?
- [ ] Does the tailpipe terminate at least 1 inch (25 mm) beyond the perimeter of the vehicle and at least 6 inches (153 mm) away from any opening into the vehicle and not under a slide-out room or near a fuel fill opening?
- [ ] Is the tailpipe routed such that it is not likely to be struck while the vehicle is moving?
- [ ] Is the genset located outside the interior space of the vehicle and separated by approved vapor-tight and fire-resistive materials?
- [ ] Are all wiring holes into the vehicle interior (inside and outside conduit connectors) sealed to keep out exhaust gas?
- [ ] Have the AC output connections been made properly.
- [ ] Have properly sized batteries and battery cables been installed?
- [ ] Have the battery cables been secured at sufficient intervals to prevent chaffing and contact

with sharp edges, fuel lines and hot exhaust parts?

- [ ] Is the genset bonding terminal (negative [-] battery cable terminal) properly grounded to the vehicle chassis?
- [ ] Are all fuel connections tight?
- [ ] Have the fuel lines been secured at sufficient intervals to prevent chaffing and contact with sharp edges, electrical wiring and hot exhaust parts?
- [ ] Is the genset protected from road splash?
- [ ] Does the genset clear the ground by at least 12 inches (305 mm)?

## STARTUP

When all installation requirements have been met, connect the battery cables to the battery, positive (+) cable first.

**▲WARNING** *Arcing at battery terminals or in light switches or other equipment, and flames or sparks, can ignite battery gas causing severe personal injury—Ventilate battery area before working on or near battery—Wear safety glasses—Do not smoke—Switch work light ON or OFF away from battery—Stop genset and disconnect charger before disconnecting battery cables—Disconnect negative (-) cable first and reconnect last.*

Read through the Operator’s Manual and perform the maintenance and pre-start checks instructed. The genset is shipped from the factory with proper levels of engine oil and coolant, which should nevertheless be checked before the genset is started. Start and operate the genset, following all the instructions and precautions in the Operator’s Manual.

**▲WARNING** *EXHAUST GAS IS DEADLY! Do not operate the genset when the vehicle is indoors unless there is ample fresh air ventilation.*

Check for fuel, coolant and exhaust leaks and unusual noises while the genset is running under full and intermediate loads. To calculate electrical loads see POWERING EQUIPMENT in the Operator’s Manual. Do not place the genset in service until all leaks have been fixed and operation is satisfactory.

## HOT AIR RECIRCULATION TEST

A representative installation of the genset must be tested to determine that the genset will not overheat due to recirculation of hot air back into the genset.

### Test Method

1. Complete a representative installation.
2. Conduct the test in a well ventilated space in which carbon monoxide cannot accumulate, but that is protected from cross drafts that could affect temperature measurements.
3. Connect a large, constant load to the genset. If a load bank is available, connect at least 3/4 full load. If not, connect and run the largest combination of constant loads that can be kept on during the test without tripping the genset circuit breaker. For example, run a combination of air conditioners, hair dryers and lights. Make sure the air conditioners stay on and do not cycle during the test.
4. Measure temperatures with thermocouples not heavier than No. 24 AWG (0.21 mm<sup>2</sup>).
5. Measure genset intake air temperature with one or two thermocouples tied about 1 inch away from the face of the radiator in the intake air opening (Figure 6-1). Make sure the thermocouples don't touch the radiator.
6. Measure ambient air temperature with a shielded thermocouple within 4 feet (1.2 me-

ters) of the genset and at approximately the same height. Make sure the thermocouple will not be affected by warm air discharged from the genset or by sunlight. Use 2 inch diameter white PVC piping at least 6 inches long as a thermocouple shield.

7. Close all genset compartment doors and run the genset for at least 90 minutes. Record temperatures at 15 minute intervals. See Table 6-1 for an example of how the data can be arranged for recording and analysis.

**TABLE 6-1. TEMPERATURE DATA TABLE**

THERMOCOUPLE LOCATION	TEMPERATURE (°F)						
	Time of Reading (Minutes)						
	0	15	30	45	60	75	90
Intake Air Temperature							
Ambient Air Temperature							
Temperature Difference (Intake – Ambient)							

### Test Requirement

The difference in temperature between genset intake air and ambient air must be no more than 5° F – 10° F after 90 minutes. A higher temperature difference indicates that hot discharged air is recirculating back into the cooling air intakes. Steps must be taken to reduce recirculation to an acceptable degree. Review VENTILATION (Page 2-2).

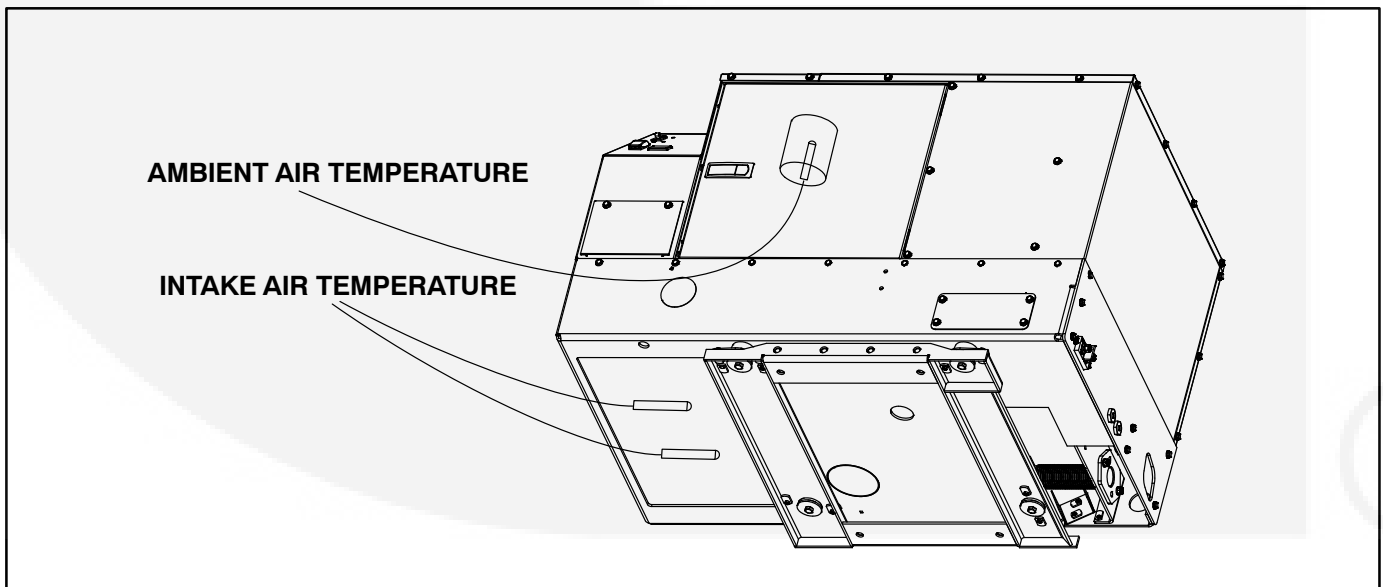

**FIGURE 6-1. THERMOCOUPLE LOCATIONS FOR HOT AIR RECIRCULATION TEST**

# 7. Specifications

<b>MODEL:</b>	<b>HDKCA</b>	<b>HDKCB</b>
<b>GENSET CONTROL:</b> Integrated Microprocessor-Based Engine and Generator Controller		
<b>GENERATOR:</b> Single-Bearing, 4-Pole Rotating Field, 1800 RPM		
Power (@1.0 power factor)	10,000 W	12,500 W
Voltage	120 / 240	120 / 240
Frequency	60 Hz	60 Hz
Number of Phases	1	1
Current	41.7 amps per leg	52.1 amps per leg
Line Circuit Breaker	2-pole, 45 amp	2-pole, 50 amp
<b>FUEL CONSUMPTION:</b>		
No-load	0.11 gph (0.41 lph)	0.11 gph (0.41 lph)
Half-load	0.48 gph (1.82 lph)	0.48 gph (1.82 lph)
Full-load	1.01 gph (3.8 lph)	1.2 gph (4.54 lph)
<b>ENGINE:</b> 3-Cylinder In-Line, Water-Cooled, Indirect-Injection (IDI), 4-Stroke Cycle Diesel		
Bore	3.43 in (87 mm)	
Stroke	3.64 in (92.4 mm)	
Displacement	100.5 in <sup>3</sup> (1,647 cc)	
Compression Ratio	22.6 : 1	
Fuel Injection Timing (BTDC)	14.50° (Spec A-B)	14.25° (Begin Spec C)
Firing Order	1-3-2	
Fuel Nozzle Injection Pressure	1991 psi (13.731 mPa)	
Cylinder Compression Test	370 psi (2.55 mPa) minimum	
Valve Lash: Intake & Exhaust (cold)	0.0071 to 0.0087 in (0.18 to 0.22 mm)	
Oil Capacity (with filter)	5.9 quart (5.6 liter)	
Cooling System Capacity	6.6 quart (6.2 liter)	
<b>DC SYSTEM:</b>		
Nominal Battery Voltage	12 volts	
Minimum Battery Capacity CCA (Cold Cranking Amps)	475 amps down to 0°F (-17°C) 650 amps down to -20°F (-29°C)	
Battery Recharging	Installer must provide for battery charging	
<b>WEIGHT:</b>	792 lbs (359 kg)	816 lbs (370 kg)
<b>SIZE (L x W x H):</b> 41.4 x 24.5 x 27 in (105 x 62 x 68.6 cm)		
<b>SOUND LEVEL:</b> 68 dB(A) @ 10 ft (3m) & 54 dB(A) @ 50 ft (15m)—in “free field site” @ half load		



**THIS PAGE IS INTENDED TO BE BLANK**



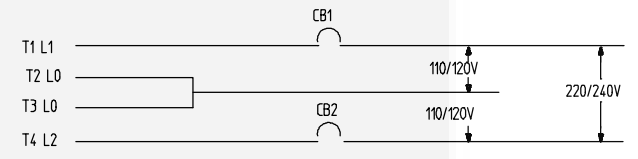
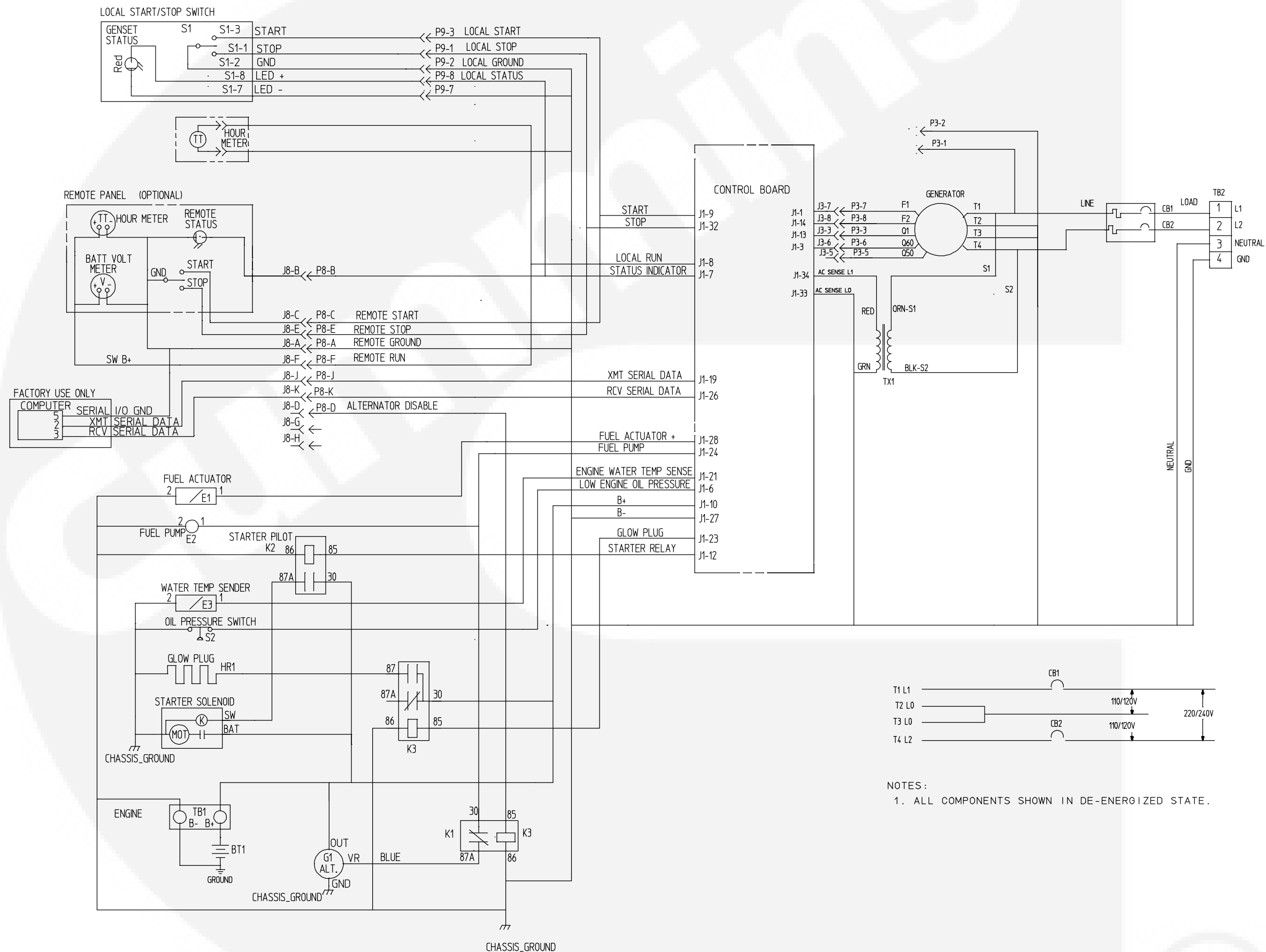

NOTES:  
 1. ALL COMPONENTS SHOWN IN DE-ENERGIZED STATE.

CONTROL SCHEMATIC

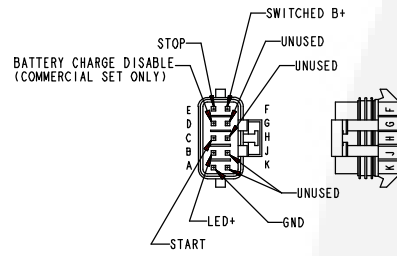
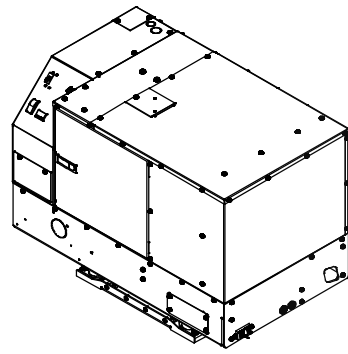

REMOTE PLUG DETAIL  
SEE NOTE 6  
SCALE 1:1

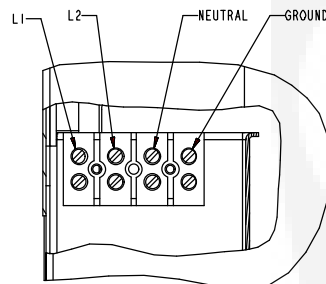

DETAIL C  
SCALE 1/1

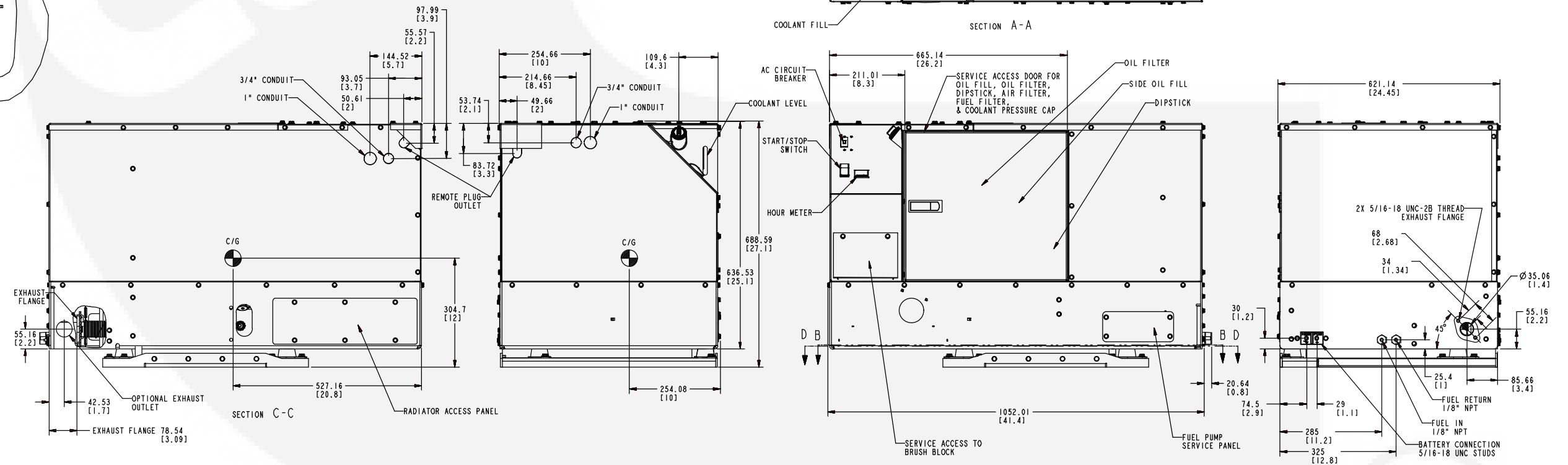
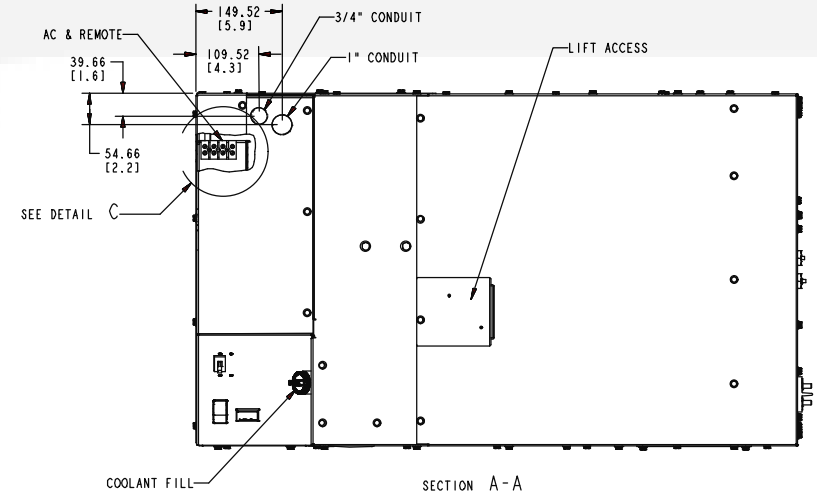
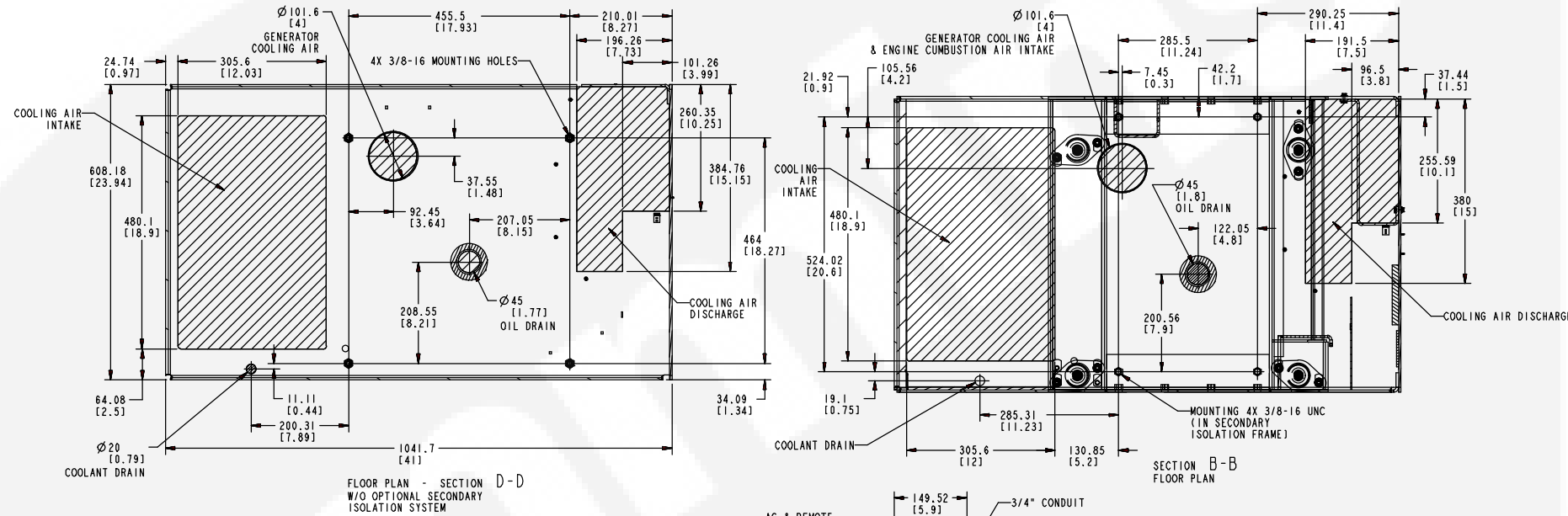

- NOTES:
- PRIMARY DIMENSIONS ARE MILLIMETERS. DIMENSIONS IN [ ] ARE INCHES.
  - COMPARTMENT SHALL ALLOW OPENING AND CLOSING OF SERVICE ACCESS DOOR AND ACCESS TO THE FOLLOWING COMPONENTS: START-STOP SWITCH, CIRCUIT BREAKER, COOLANT FILL AND CHECK, AND COOLANT DRAIN.
  - MINIMUM UNIT CLEARANCE FROM COMPARTMENT SURFACES:  
TOP 12.5 [0.50]  
ALL SIDES 6.4 [0.25]
  - MINIMUM INSTALLATION SIZE IS 697.1 [27.5] HIGH X 633.8 [25] WIDE X 1097 [43.2] LONG AND VARIES WITH MOUNTING KIT USED AND SERVICE DOOR ACCESS.
  - MATES WITH PACKARD METRI-PACK™ CONNECTOR
- | DESCRIPTION  | QTY | PACKARD PART NO. | ONAN PART NO. |
|--------------|-----|------------------|---------------|
| CONNECTOR    | 1   | 12045808         | 323-1710      |
| PLUG-CAVITY  | 3   | 12059168         | 323-1712      |
| SEAL CABLE   | 7   | 12048086         | 323-1708      |
| TERMINAL     | 7   | 12045773         | 323-1707      |
| HOUSING-LOCK | 1   | 12176336         | 323-1719      |
- THESE TERMINALS AND HOUSING ARE DESIGNED TO BE USED WITH 18-22 GAUGE WIRE ONLY. SEE ACCESSORY CATALOG FOR COMPLETE MATING HARNESSSES.
- UNIT WEIGHT:  
10 kw - 356.5 KG [786 lbs]  
12.5 kw - 370.1 KG [816 lbs]

OUTLINE DRAWING

A-2

500-4040





# Cummins **Onan**

## **Cummins Power Generation**

1400 73rd Ave. NE  
Minneapolis, MN 55432 USA

Phone 1 763 574 5000

Toll-free 1 800 888 6626

Fax 1 763 574 5298

Email [www.cumminsonan.com/contact](http://www.cumminsonan.com/contact)

[www.cumminsonan.com](http://www.cumminsonan.com)

Cummins®, Onan®, the "C" logo, and "Performance you rely on." are trademarks of Cummins Inc.

©2012 Cummins Power Generation, Inc. All rights reserved.

